

REV.	DATE	ECN NO.	MODIFICATION	APPROVER
A	2012/12/09	/	NEW	MIKE
A1	2014/10/08		尺寸公差更新	Jason

Specifications:

1. Electrical:
 - 1.1 Current Rating:1.5A
 - 1.2 Voltage Rating:30V DC
 - 1.3 Contact Resistance:30mΩ Max
 - 1.4 Dielectric Withstanding Voltage:500V AC AT
 - 1.5 Insulation Resistance:1000MΩ min
2. Mechanical:
 - Mating Force:4.0KG MAX
 - Unmating Force:0.7KG MIN
3. Material:
 - 3.1. Housing:Hing Temperature Thermoplastics PBT/LCP UL94V-0,Color: White/Black
 - 3.2. Contact:Copper Alloy C2680
 - 3.3.Shell:Spcc
4. Finish:
 - Contact:Plated Gold in Mating Area;
 - Tin on Solder Tails
 - Shell:Nickel plating

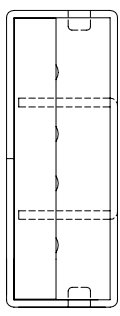
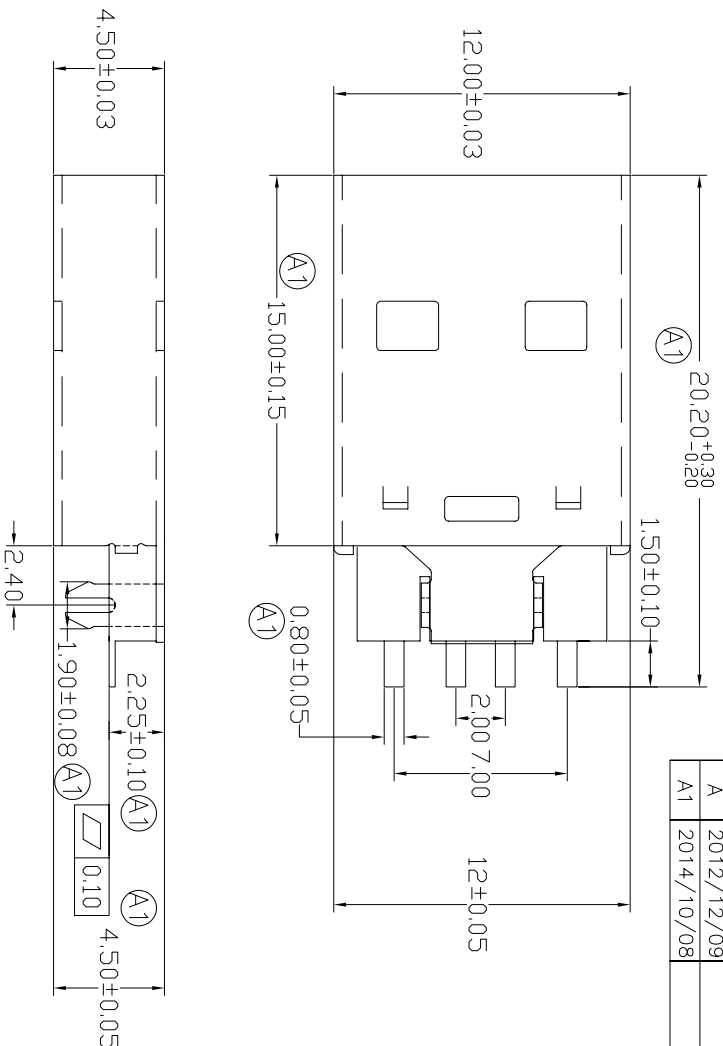
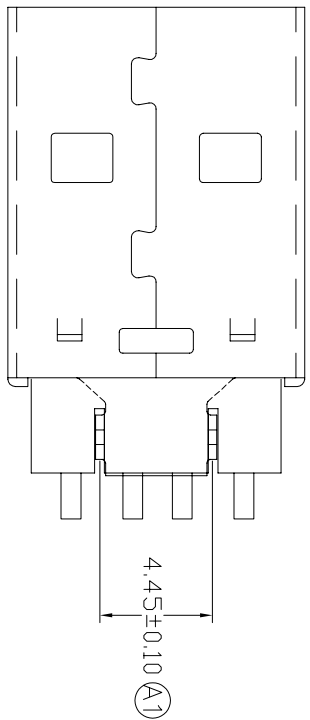
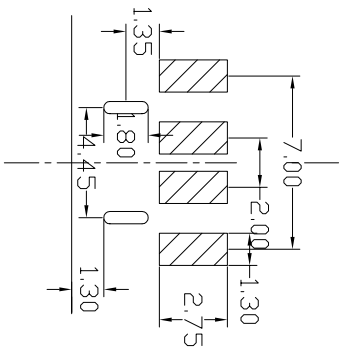

GENERAL TOLERANCE		UNITS mm		NAME: USB	
SELECT	✓	1	2	3	
TOL	1	2	3		
ON	1	2	3		
X.XXX	±0.10	±0.05	±0.15		
X.XX	±0.15	±0.13	±0.25		
X.X	±0.20	±0.25	±0.50		
X.	±0.30	±0.38	±1.00		
ANGLE					
FINISH		MATING		TITLE: USB A/M 4P SMT 鱼叉式	
QTY		QTY		PART NO: USB304MA-C1008***	
DR: Anna		CHKD: Vicky		APPD: Jason	
DWG NO. ATOM-A00906		SCALE 1:1		SHEET 1/1	
		REV A1			