

REV.	DATE	ECN NO.	MODIFICATION	APPROVER
A	2016/03/21	/	NEW	Vicky

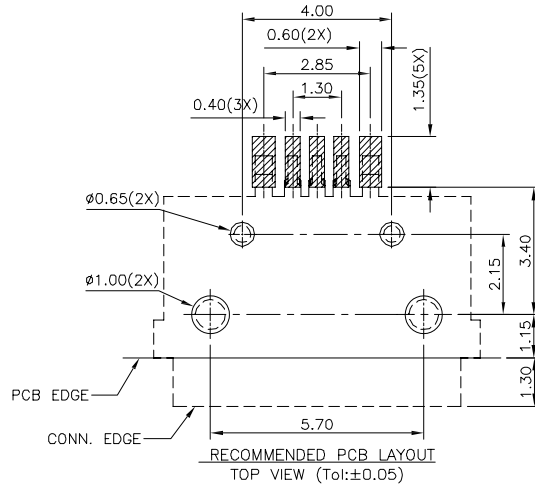

NOTES:

- CONTACT CURRENT RATING: 1.0A(SIGNAL PIN2,3,4);2.0A(POWER PIN1,5).
- CONTACT RESISTANCE: 30mΩ MAX.;
- INSULATION RESISTANCE: 1000MΩ MIN.;
- DIELECTRIC WITHSTANDING: 100V AC MIN.;
- DURABILITY: 5,000 CYCLES MIN.;
- CONNECTOR MATING FORCES: 25N (2.55Kgf)MAX.;
- CONNECTOR UNMATING FORCES: 2~25N (0.20~2.55Kgf);

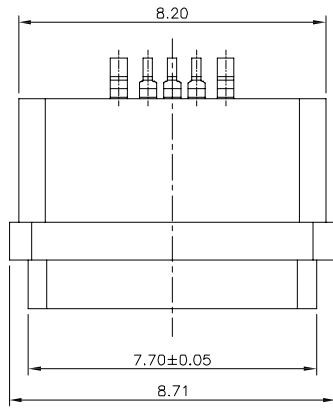
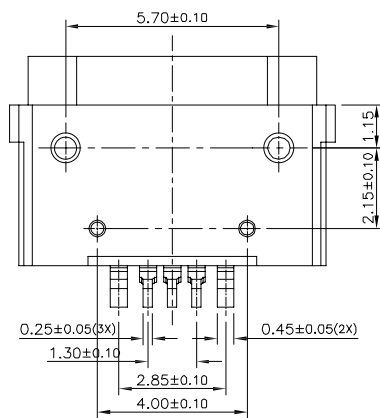
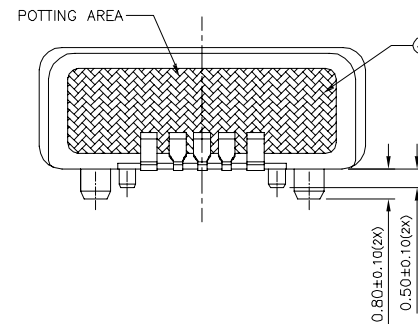
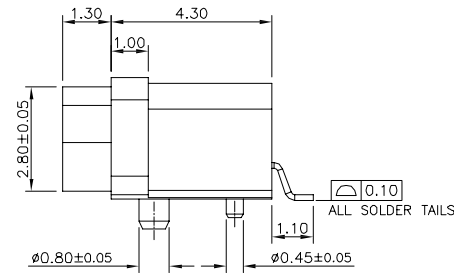
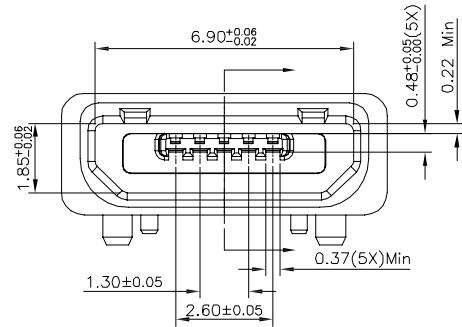

01	HOUSING	1 PCS	HIGH TEMPERATURE PLASTIC	BLACK COLOR, UL94V-0;
02	CONTACT A	1 PCS	COPPY ALLOY	Ni:40~160u";Au:CONTACT AREA:3u",SOLDER:1u",OTHER AREA:G/F
03	PLASTIC SHELL	1 PCS	HIGH TEMPERATURE PLASTIC	BLACK COLOR, UL94V-0;
04	GLUE	1 PCS	EPOXY RESIN	BLACK COLOR,
ITEM	PART NAME	Q'TY	MATERIAL	DESCRIPTION

GENERAL TOLERANCE		UNITS	NAME: MICRO USB	
SELECT	✓	mm	PART NO: USB205FB-C1005206	
TOL.	1 2 3	MAT'L	TITLE: MICRO USB 5P FEMALE SMT B TYPE 帶定位柱 防水型	
ON.	1 2 3	FINISH	APPD: Vicky	DWG NO. ATOM-A02999
X.XXX	±0.10 ±0.05 ±0.15	Q'TY	CHKD: Doris	SCALE SHEET REV
X.XX	±0.15 ±0.13 ±0.25		DR: Jillian	1:1 1/1 A
X.X	±0.20 ±0.25 ±0.50			
X.	±0.30 ±0.38 ±1.00			
ANGLE	±2'			