

REV.	DATE	ECN NO.	MODIFICATION	APPROVER
A	2012/12/12	/	NEW	Vicky
B	2016/10/12	RD00316101201	外壳铆合变更, 详见B处	Vicky

NOTE:

1. MATERIAL:
 - 1.1 Housing: LCP UL94V-0;
 - 1.2 Terminal: C2680R-H, Semi Gold and Tin, Au 1U" plated on contact, matte Tin plated 100u";
 - 1.3 Shell: SUS, Matte Tin plating 80u" on surface;
2. MAIN FEATURES:
 - 2.1 Rating current: 1A;
 - 2.2 Contact resistance: 50mΩ MAX;
 - 2.3 Insulation resistance: 100MΩ MIN 250V DC;
 - 2.4 Withstanding voltage test: 250V AC;
 - 2.5 solderability: Temperature 235±5°C, time 5±0.5s;
 - 2.6 Pin retention force: 0.5kgf MIN;
 - 2.7 Overall insertion force: 3.57kgf MAX
Overall extraction force: 1.00kgf MIN;
 - 2.8 Life cycle: 10000 cycles
 - 2.9 Resistance to temperature:
 - 2.9.1 Oven test: Temperature: 250±5°C, time 2 mins;
 - 2.9.2 Operating temperature: -30°C~+80°C.

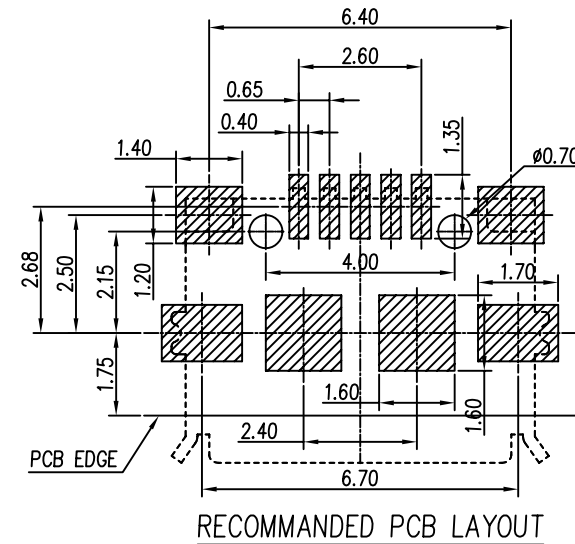
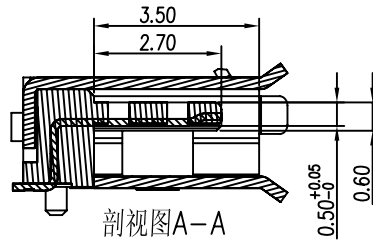
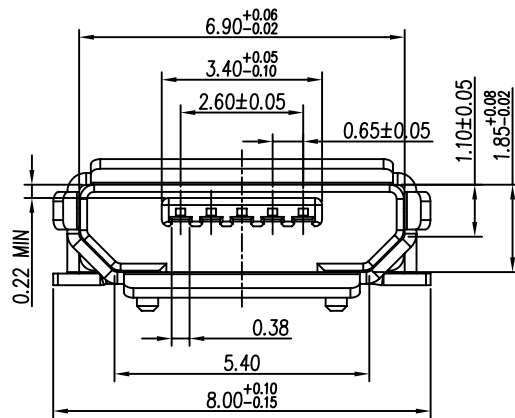
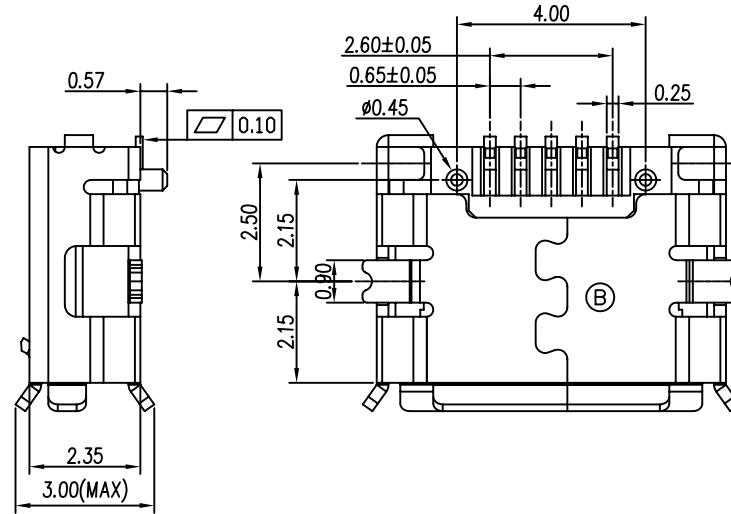
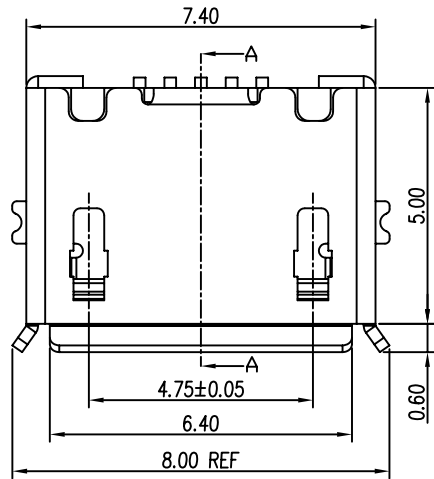

GENERAL TOLERANCE				UNITS	NAME: USB				
SELECT	✓			mm	PART NO: USB205FB-C1005205				
TOL.	1	2	3	MAT'L	TITLE: MICRO USB 5P FEMALE SMT B TYPE 带定位柱 外壳有翻边				
ON.	X.XXX	±0.05	±0.05 ±0.15	FINISH	APPD: Vicky	DWG NO. ATOM-A01823			
	X.XX	±0.15	±0.13 ±0.25	Q'TY	CHKD: Emilia		SCALE	SHEET	REV
	X.X	±0.25	±0.25 ±0.50		DR: Doris		1:1	1/1	A
	X.		±0.38 ±1.00						
	ANGLE	±1°							