

REV.	DATE	ECN NO.	MODIFICATION	APPROVER
A	2016/05/15	/	NEW	Vicky

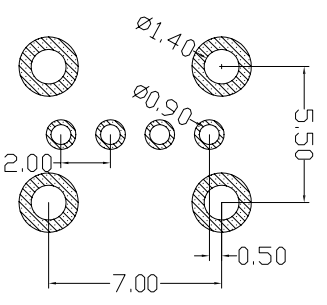
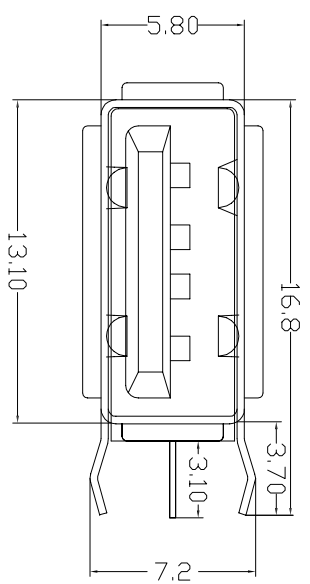
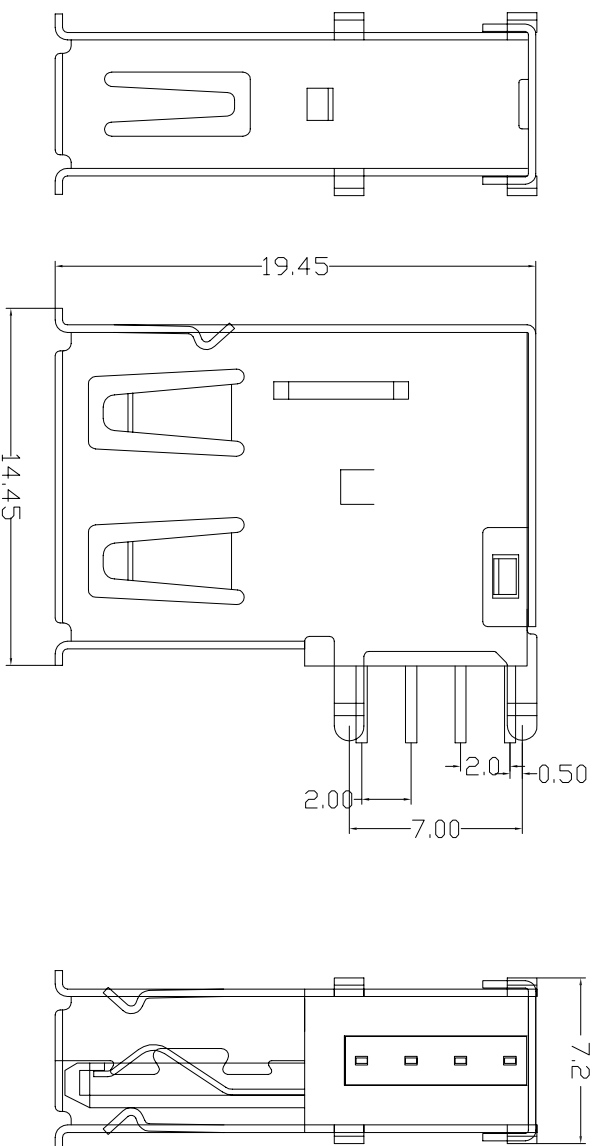

PCB LAYOUT

Specifications:

Electrical:

- Current Rating 1.5A/contact terminal
- Voltage Rating 30V DC
- Contact Resistance 30 milliohms MAX
- Dielectric Withstanding Voltage: 500 V AC AT Sea Level
- Insulation Resistance: 1000MEGA ohms MIN

Mechanical:

- Connector Mate and Unmate Force  
Mate force: 3.75kgf (MAX)  
Unmate force: 1.02kgf (MIN)
- Terminal Retention: 1.2kgf (MIN)

Material:

- Housing:  
High Temperature Thermoplastics,  
UL 94V-0 PBT White/Black
  - Contact: Copper Alloy C2680
  - Shell: SPCC/Copper Alloy C2680
- Finish:
- Contact: Plated Gold in Mating Area;  
Tin On Solder Tails
  - Shell:  
Nickel Plating

GENERAL TOLERANCE			UNITS		NAME:	
SELECT	TOL		mm		USB	
ON	1	2			PART NO:	
X.XXX	±0.10	±0.08			USB304FA-A1010***	
X.XX	±0.20	±0.13			APPD:	
X.X	±0.30	±0.25			Vicky	
X.	±0.38	±1.00			CHKD:	
ANGLE	±2°				Doris	
					DR:	
					Cmy	

TITLE: USB A/F 4P DIP 90°侧插 外壳脚 7.20		DWG NO.		ATOM-A03052	
SCALE	SHEET	SCALE	SHEET	SCALE	SHEET
1:1	1/1	1:1	1/1	1:1	1/1
REV		REV		REV	
A		A		A	